

INSTALLATION INSTRUCTIONS

Revision B1
Rapid City, SD, USA, 07/2009

PumpSaver® ELECTRONIC PUMP CONTROL & PROTECTION

MODEL 233P/111P/233P-1.5



IL_111P-233P-1.5P_B1

DANGER!



HAZARDOUS VOLTAGES MAY BE PRESENT DURING INSTALLATION.

Electrical shock can cause death or serious injury.

Installation should be done by qualified personnel following all national, state and local electrical codes.



**BE SURE POWER IS DISCONNECTED PRIOR TO INSTALLATION!
FOLLOW NATIONAL, STATE AND LOCAL CODES.
READ THESE INSTRUCTIONS ENTIRELY BEFORE INSTALLATION.**

SymCom's PumpSaver[®]Plus is a pump monitor designed to protect single-phase pumps from dry-well, dead-head, jammed impeller, rapid-cycling, overvoltage and undervoltage conditions. The PumpSaver[®]Plus Model 233P protects 230V, 2 or 3-wire, 1/3 to 3 hp pumps. The PumpSaver[®]Plus Model 233P-1.5 protects 230V, 2 or 3-wire, 1/3 to 1.5 hp pumps. The PumpSaver[®]Plus Model 111P protects 115V, 2 or 3-wire, 1/3 to 1 hp pumps. Typical applications include submersible pumps, centrifugal pumps, circulating pumps, cooling pumps, environmental pumps, residential waterwells, commercial waterwells, irrigation wells, and golf course and other sprinkler systems.

CONNECTIONS

NOTE: Use with UL/CSA listed overload or impedance protected pumps or motors only.

1. Mount the PumpSaver[®]Plus in a convenient location in or near the pump control box. If the location is wet or dusty a NEMA 3R, 4, or 12 enclosure should be used. The PumpSaver[®]Plus must be protected by a fuse or circuit breaker (30A RK5 fuse or 30A inverse time breaker max).
2. Connect one line from the fused disconnect to the **L1 IN** terminal of the PumpSaver[®]Plus. Run a wire from the **L1 OUT** terminal to the other in-line controls such as pressure or float switches.
3. Connect the other line from the fused disconnect (ungrounded fused conductor) to the **L2 IN** terminal of the PumpSaver[®]Plus. Run a wire from the **L2 OUT** terminal to the other in-line controls such as pressure or float switches (see Figure 1).
4. Refer to the appropriate wiring diagram for your specific application:
 - Typical wiring diagram – Figure 1
 - Standard 3-wire control box – Figure 2
 - Deluxe control box – Figure 3
 - 2-Wire pump direct feed – Figure 4

***** WARNING *****

PROPER OPERATION REQUIRES FIELD CALIBRATION

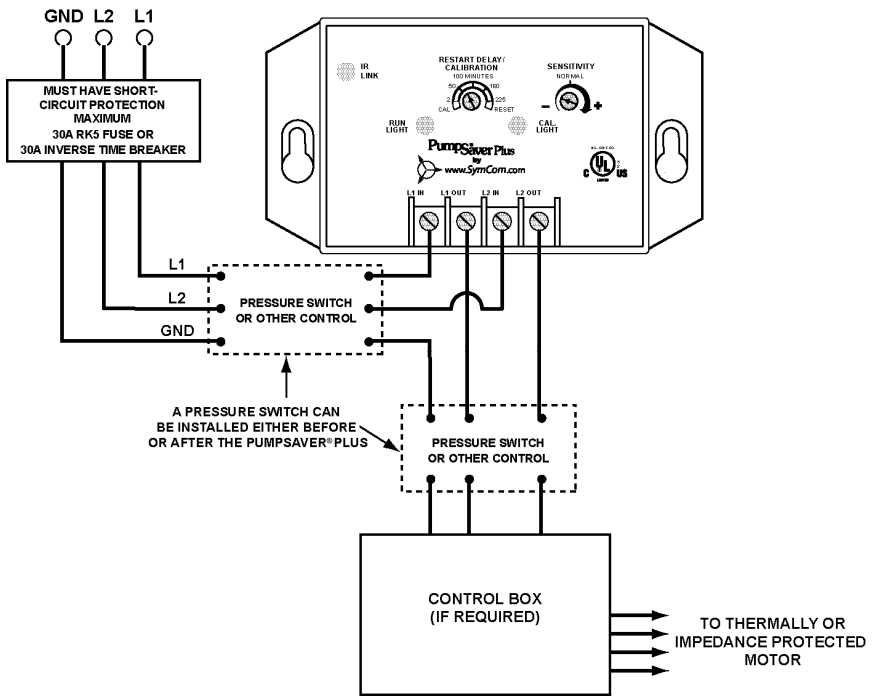

FIGURE 1: Typical Wiring Diagram

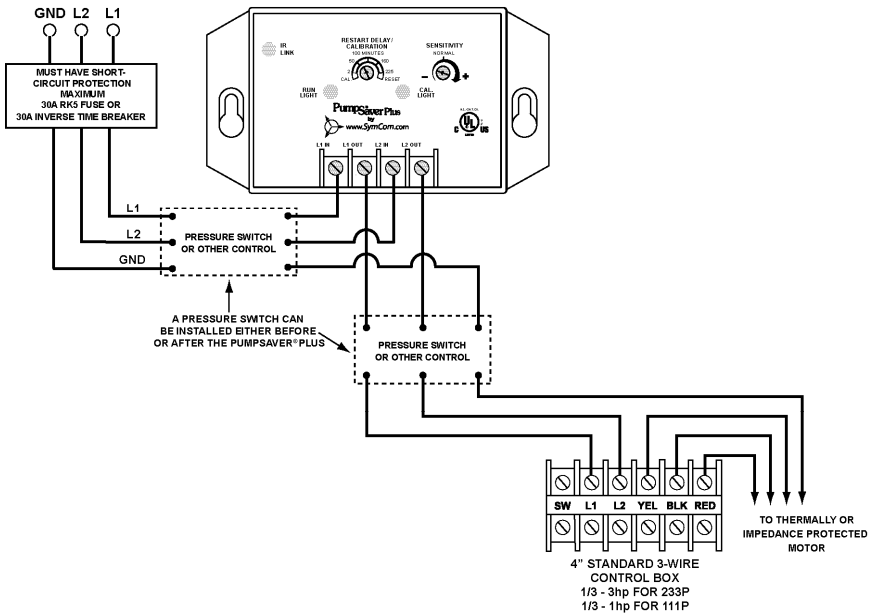

FIGURE 2: Standard Control Box Wiring Diagram

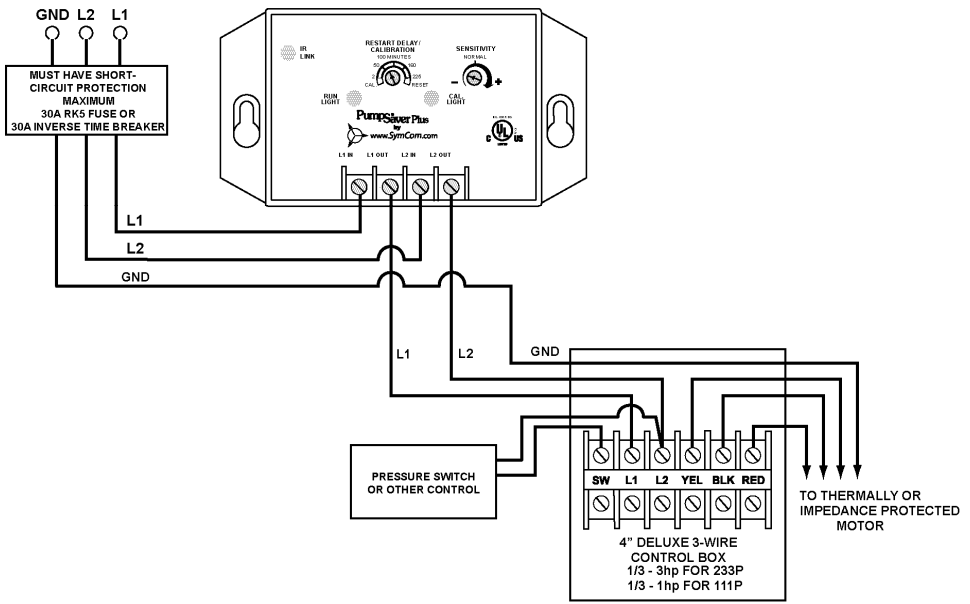

FIGURE 3: Deluxe Control Box Wiring Diagram

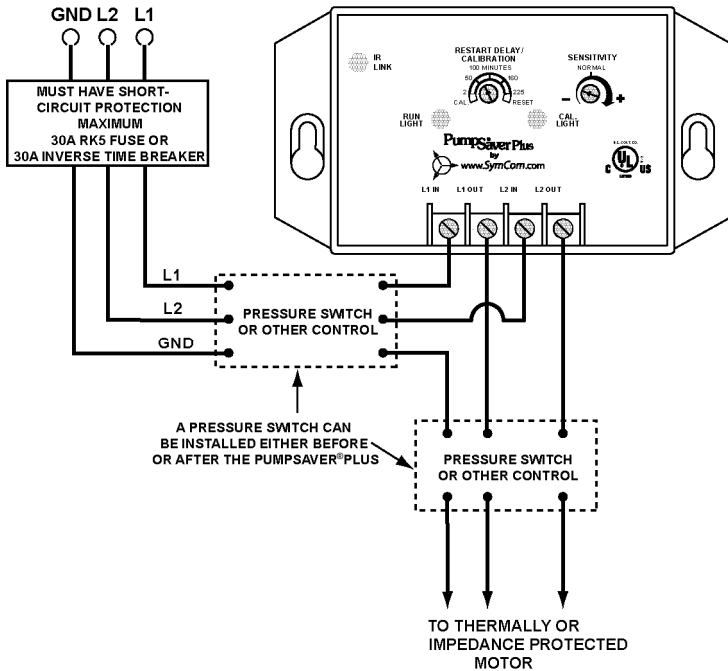

FIGURE 4: 2-Wire Pump Direct-Feed Wiring Diagram

OPERATION

The PumpSaver®Plus monitors pump load in amps and kilowatts. When the current (amps) exceeds approximately 125% of calibrated current, or power (kW) drops below the adjustable underload trip point, the PumpSaver®Plus—after the trip delay—will turn off the pump. The PumpSaver®Plus will time through the restart delay, and then restart the pump. The calibration is stored in permanent memory—it **does not need to be recalibrated if power is lost**.

CALIBRATION

NOTE: The PumpSaver®Plus should be calibrated during normal pumping conditions.

1. Turn the **RESTART DELAY/ CALIBRATION** knob fully counter-clockwise to the **CAL.** position.
2. Apply power—the pump will run for approximately 10 seconds then shut off.
3. Set the **RESTART DELAY/ CALIBRATION** knob to the desired restart delay (dry-well recovery time)—the pump will turn on.

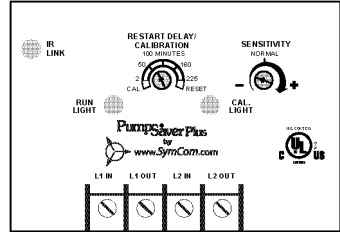

CALIBRATING WHILE PUMPING

The PumpSaver®Plus can also be calibrated while the pump is running. Turn the **RESTART DELAY/ CALIBRATION** knob to **CAL.** while pumping. Wait for the pump to turn off (approximately 10 seconds), then adjust the **RESTART DELAY/ CALIBRATION** knob to the desired setting.

SENSITIVITY

The PumpSaver®Plus has an adjustment knob to set the underload trip sensitivity. Setting **SENSITIVITY** to the middle position (straight up) is equivalent to SymCom's standard underload trip level. Adjust the **SENSITIVITY** knob to increase/decrease underload sensitivity up to approximately 10% of the standard trip. It may be necessary to increase the sensitivity if the PumpSaver®Plus does not trip on dry-run or dead-head or it is known that the water level in the well is very low relative to the pump's capabilities.

WARNING: Decreasing the SENSITIVITY may compromise the PumpSaver®Plus' ability to detect dry-run and/or dead-head conditions.

RESET MODE / RESTART DELAY

Any restart delay can be by-passed by rotating the **RESTART DELAY/ CALIBRATION** knob to the **RESET** position and back to the desired restart delay setting.

NOTE: The restart delay setting can be changed at any time. The current and subsequent trips will follow the new restart delay setting.

The **RESTART DELAY/ CALIBRATION** knob can be placed in the **RESET** position for manual reset. If the PumpSaver®Plus trips off in this mode due to a voltage or load problem, the **RESTART DELAY/ CALIBRATION** knob must be rotated out of the **RESET** position to restart the pump.

RUN HOURS / FAULT HISTORY

The PumpSaver®Plus records pump run hours. Run hours can be displayed by a PumpSaver® Informer (see **USING AN INFORMER** at the bottom of this page). Run hours and fault history can be cleared on the PumpSaver®Plus. Read the following instructions fully before performing the procedure.

NOTE: Turn the SENSITIVITY knob completely to the left (counter-clockwise) or completely to the right (clockwise) when directed.

To Reset Run Hours and Clear Fault History:

1. Remove power to the PumpSaver®Plus.
2. Set the **RESTART DELAY/ CALIBRATION** knob to **RESET** and the **SENSITIVITY** knob to the middle (12:00) position.
3. Apply power to the PumpSaver®Plus—the **CAL. LIGHT** will turn on.
4. Turn the **SENSITIVITY** knob to the **right**—the **CAL. LIGHT** will turn off and the **RUN LIGHT** will turn on.
5. Turn the **SENSITIVITY** knob to the **left**—both lights will turn on.
6. Turn the **SENSITIVITY** knob to the **right**.
7. After 10 seconds, the **CAL.** and **RUN LIGHTS** will blink twice indicating the run hours and fault history have successfully been cleared.

RAPID CYCLING

Rapid cycling is defined as more than 4 restarts in a 60-second period. The PumpSaver®Plus is capable of detecting a rapid-cycle condition whether a control device, such as a pressure switch, is installed before* or after it. Upon detecting either form of rapid cycling, the PumpSaver®Plus will lock-out, preventing damage to the pump. To reset the PumpSaver®Plus, remove and re-apply power.

RAPID CYCLING (Line Side / Upstream)

Rapid cycling of the line side of the PumpSaver®Plus may be caused by several naturally occurring conditions which are indistinguishable from true rapid cycling. For this reason, once tripped, the PumpSaver®Plus will wait 30 minutes and restart. If the restart is successful (the pump runs for more than one minute), the rapid cycle counter will reset to zero. If the PumpSaver®Plus encounters rapid cycle 4 times without a successful restart, it will lock-out and require a manual reset. To reset the PumpSaver®Plus, remove and re-apply power.

*Protection against rapid cycling of a control device installed **before** the PumpSaver®Plus is disabled by default. Read the following instructions fully before performing the procedure to enable this feature.

NOTE: Turn the SENSITIVITY knob completely to the left (counter-clockwise) or completely to the right (clockwise) when directed.

To Enable Rapid-Cycle Protection when a Control Device is Installed BEFORE the PumpSaver®Plus: (to disable, follow the same procedure)

1. Remove power to the PumpSaver®Plus.
2. Set the **RESTART DELAY/ CALIBRATION** knob to **RESET** and the **SENSITIVITY** knob to the middle (12:00) position.
3. Apply power to the PumpSaver®Plus —the **CAL. LIGHT** will turn on.
4. Turn the **SENSITIVITY** knob to the **right**—the **CAL. LIGHT** will turn off, **RUN LIGHT** will turn on.
5. Turn the **SENSITIVITY** knob to the **left**—both lights will turn on.
6. Turn the **SENSITIVITY** knob **right—left—right—left—right**.
7. After 2 seconds, the **CAL.** and **RUN LIGHTS** will blink once indicating line side rapid-cycle

protection has been enabled.

RAPID CYCLING (Load Side / Downstream)

Load side rapid cycling of the pump will immediately result in a manual lock-out. The pump will not restart automatically. To reset the PumpSaver®Plus, remove and re-apply power.

Note: Protection against rapid cycling of a control device installed **after** the PumpSaver®Plus is always enabled. Disabling line side detection will **not** disable load side detection.

USING AN INFORMER

PumpSaver®Plus products are equipped with an infrared LED that will communicate to a SymCom Informer—a handheld, battery-operated, diagnostic tool. The Informer—when directed at the PumpSaver®Plus—will display real-time voltage, current and power; dry-well and overcurrent trip points; calibration voltage; last 20 faults; voltage, current and power at the last fault; highest/lowest voltage and current since calibration; the model number; and the CT size if applicable. The Informer can be used on any single-phase PumpSaver®Plus equipped with an infrared LED transmitter. Contact SymCom for more information at 800-843-8848 or visit our website: www.symcom.com.

TROUBLESHOOTING

RUN LIGHT	CAL. LIGHT	PROBLEM or FUNCTION	CORRECTIVE ACTION
On Steady	Off	RUN: Pump is running—or ready to run—no problems in operation	If pump is not running, check for loose wiring and ensure proper function of pressure or float switches.
On Steady	On Steady	CAL: The PumpSaver®Plus is in the calibration process.	None
Off	On Steady	CAL COMPLETE: The PumpSaver®Plus has calibrated, the RESTART DELAY/ CALIBRATION knob was left in the CAL. position. Pump is off.	Pump will restart as soon as the RESTART DELAY/ CALIBRATION knob is rotated out of the CAL. position.
Off	Off	OFF / MANUAL RESTART: The pump is not running. Either the PumpSaver®Plus has tripped on dry-run, dead-head, or overcurrent while the RESTART DELAY/ CALIBRATION knob was in the RESET position or source power is not present.	If knob is in the RESET position, rotate out of RESET —If the CAL. light blinks, check for an overcurrent condition. If the RUN light blinks, look for a dry-run or dead-head condition. If no lights come on, check incoming power for adequate voltage.
Blinking	Off	DRY RUN / DEAD HEAD: The PumpSaver®Plus has shut the pump off due to a dry run or dead head condition. The unit is timing through the restart delay and will try to restart.	Check for restricted flow or inadequate supply of liquid.
Off	Blinking	OVERCURRENT: The PumpSaver®Plus has shut the pump off due to an overcurrent condition. The unit is timing through the restart delay and will try to restart if line voltage is at an acceptable level.	Check for low or high voltage or jammed pump impellers. If these conditions do not exist, recalibrate the unit while it is drawing higher current (amps should not exceed SFA).
Blinking alternately with the CAL. LIGHT	Blinking alternately with the RUN LIGHT	VOLTAGE FAULT: The PumpSaver®Plus is preventing the pump from starting due to voltage problems. The voltage is being interrogated and the unit will remain in this mode until the voltage is at an acceptable level.	If the unit remains in this state for more than 5 seconds, check for high or low voltage.
Blinking in unison with the CAL. LIGHT	Blinking in unison with the RUN LIGHT	RAPID CYCLE: The PumpSaver®Plus has shut down on rapid cycling. Power must be removed and reapplied to reset the unit.	Check for a broken bladder in the pressure tank (if used), or check for a defective pressure or float switch.

PHYSICAL DIMENSIONS

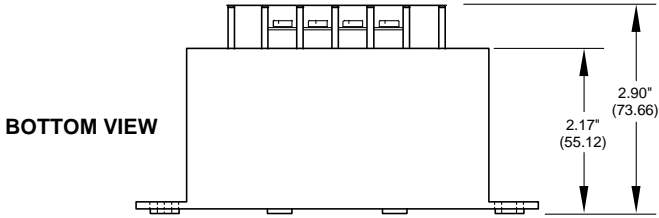
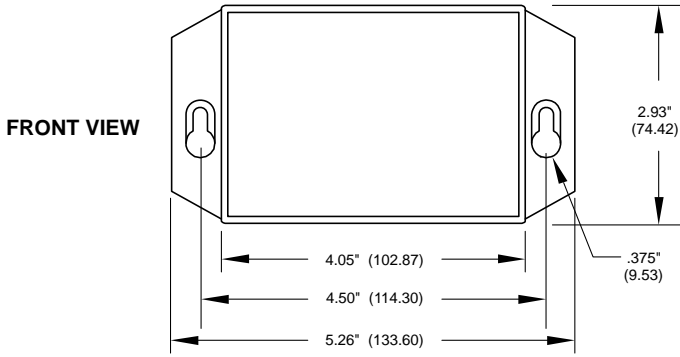

SPECIFICATIONS

Functional Specifications	
Adjustments/Settings	
Overcurrent	125% of calibration point
Underload (dry-well)	Adjustable (70-90% of calibrated run power)
Overvoltage	
233P, 233P-1.5	265VAC
111P	132.5VAC
Undervoltage	
233P, 233P-1.5	190VAC
111P	95VAC
Number of restarts allowed in 60 second period (rapid-cycling)	4
Trip Delay Times	
Overcurrent	5 seconds
Dry-well	4 seconds
Dry-well Optional*	8 seconds
Restart Delay Times	
Over/undervoltage	2 seconds
All other faults	Manual, 2-225 minutes
Input Characteristics	
Supply Voltage	
233P, 233P-1.5	230VAC
111P	115VAC
Load Range	
233P	1/3 – 3 hp
233P-1.5	1/3 – 1.5 hp
111P	1/3 – 1 hp
Frequency	50/60Hz
	(NOTE: 50Hz will increase all delay timers by 20%)
Output Characteristics	
Output Contact Rating-SPST	
233P	3hp @ 240VAC (17 Amps max.)
233P-1.5	1.5hp @ 240VAC (10 Amps max.)
111P	1hp @ 120VAC (16 Amps max.)
General Characteristics	
Operating Temperature	-40° to 55°C (-40° to 131°F)
Maximum Input Power	5 W
Wire Gauge	Solid or stranded 10 – 22 AWG
Terminal Torque	13 in.-lbs.
Standards Passed	
Electrostatic Discharge (ESD)	IEC 61000-4-2, Level 2, 4kV contact, 6kV air
Surge Immunity	IEC 61000-4-5, Level 4, 4kV line-to-line and line-to-ground
Safety Marks	
cUL Listed	UL508 & C22.2 No. 14
Dimensions	2.90" H x 5.26" W x 2.93" D
Weight	14 oz.
Mounting Methods	#8 screws

*use part number 233P-UCTD8

NOTES

For warranty information, please see **Terms and Conditions** at
www.symcom.com

*Visit us at www.symcom.com to see
our complete product listing!*

Need something special?

*Contact SymCom today
for your custom solution!
800-843-8848*

MOUNTING YOUR SYMCOM ENCLOSURE

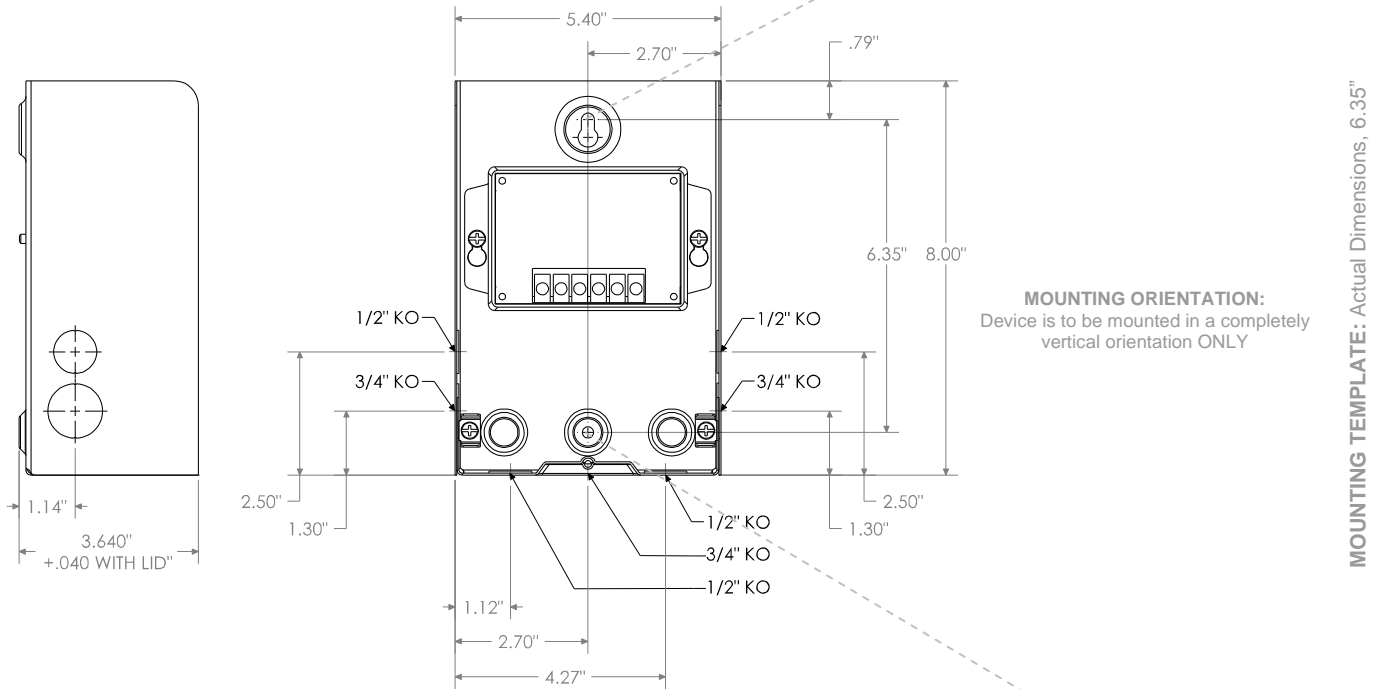

PumpSaver®Plus mounted in SymCom enclosure, Front View.

- 1) Mount the steel enclosure in the desired location using two #10 screws and the two provided gaskets. A mounting template is provided above.
- 2) Use UL listed raintight or wet location hubs to route wires into and out of the enclosure.
 - a. Seven knockouts (KO) are provided for wire routing.
 - b. Two grounding terminals are provided inside the enclosure.

WARNING! Wiring is to be routed so it does not come into contact with and is at a minimum 3/8 inch distance from Cover or Bottom of Enclosure.

- 3) See the inside cover of the enclosure for a PumpSaver®Plus wiring diagram and refer to the PumpSaver®Plus Installation Instructions for more details.
- 4) Secure the cover onto the enclosure using the screw provided.